	No.: 62-90119-00	Rev: D
Title: Compressor Terminal Wiring Instructions	Supersedes:	Page: 1 of 5

O6DR Terminal Block Installation Instructions

(Single or Dual voltage compressor)

Kit Contents:

Item No.	DV kit (76-50211-00)	SV kit (76-50210-00)	Part Number	Part Description
1	8	3	22-01881-00	Wiring assembly 12 AWG
2	1	0	69NT35-577-1	Wiring assembly 12 AWG Ring Terminal
3	2	2	22-01881-01	Wiring assembly 16 AWG
4	11	5	6DZ5001BZ	Seal, O-Ring
5	11	5	66U2-1122	Bushing (Isolator)
6	20	5	66U1-3803-1	Heat shrink tube 1/2"
7	22	5	66-U---1---3803	Heat shrink tube 1/4"
8	11	5	AT14QA172	Nut, Jam (torque nut)
9	11	5	AU04AZ301	Torque Flat Washer
10	11	5	AU11AG171	Torque Spring Lock washer
11	1	1	62-90119-00	Instructions, Technical

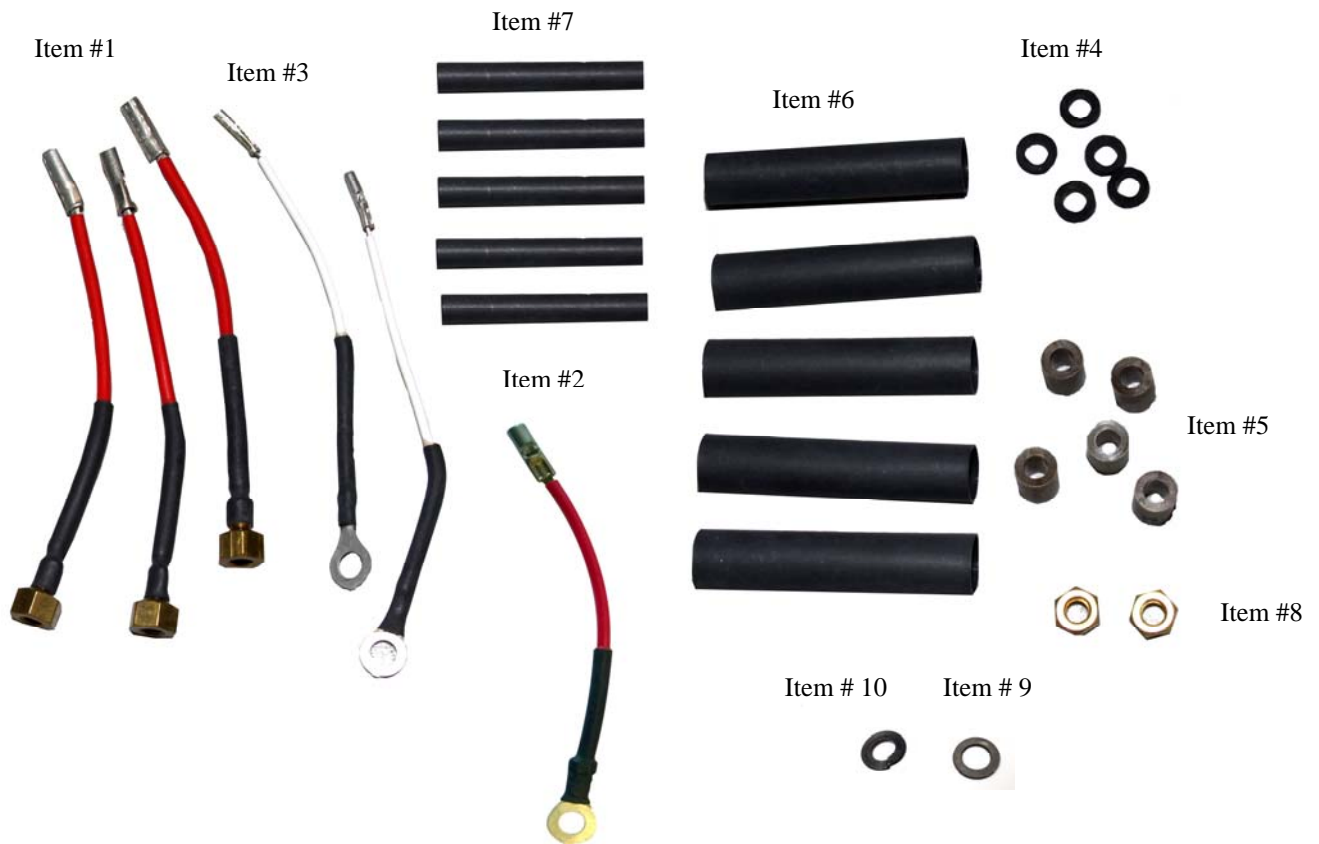

<u>Used On:</u>	<u>Prepared By:</u>	<u>Approved By:</u>	<u>Date:</u>
-----------------	---------------------	---------------------	--------------

	No.: 62-90119-00	Rev: D
Title: Compressor Terminal Wiring Instructions	Supersedes:	Page: 2 of 5



Before beginning any modifications, turn unit off and disconnect power to unit. Electrical shock can result in personal injury or death.

FOLLOW REGIONAL LOCKOUT TAGOUT PROCEDURES BEFORE PROCEEDING

INSTRUCTIONS FOR REPLACING AN 06D COMPRESSOR TERMINAL BLOCK (dual or single volage)

If a service compressor is being installed into a unit it is recommended the terminal block wiring be added to the compressor prior to installation into the unit. New insulators and rubber bushings are not required. For a single voltage compressor follow steps 10-15 and 25 – 33, for a dual compressor follow steps 10 -33

If you are only changing the compressor terminal block on a single voltage compressor, all work can be completed from the front of the unit and it is unnecessary to remove the compressor.

If you are using a dual voltage compressor for either a single or dual voltage operation it is necessary to remove the compressor to gain access to the rear terminal block.

This procedure can also be used when installing or replacing a terminal kit with either single or dual voltage compressor

Front Terminal Block

1. With the unit off, disconnect the power plug from the electrical source and remove the cover from the terminal box.
2. Using wire cutters, cut the power leads and the two compressor overload leads as close to the compressor terminals as possible.
3. Remove the two retaining screws holding the cover box to the compressor (located on the bottom right hand side of the box).
4. Check to verify there is sufficient wire length between the compressor terminal box and the high pressure switch to allow removal of the box. Slide the box off the compressor.
5. Remove the compressor wires from the terminals.
6. Remove the retaining nuts and washers from the terminals.
7. Remove the insulator and rubber bushings and discard.

RE-ASSEMBLING THE TERMINAL BLOCK

<u>Used On:</u>	<u>Prepared By:</u>	<u>Approved By:</u>	<u>Date:</u>
-----------------	---------------------	---------------------	--------------

	No.: 62-90119-00	Rev: D
Title: Compressor Terminal Wiring Instructions	Supersedes:	Page: 3 of 5

- Place the small O-Ring (item # 4) over each of the terminal stud, followed by new insulator bushing (item # 5), torque flat washer (item #9), torque lock washer (item # 10) and torque nut.
- Using a 7/16" deep socket and a torque wrench, torque each nut to the terminal block, 24-30 inch lbs. (3.0 – 3.4 N-m).

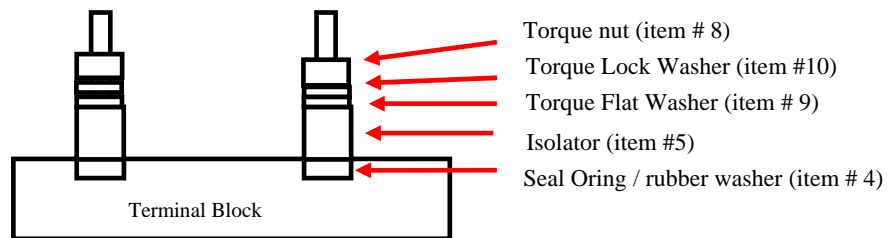

- Assemble the three red power wires (item#1) on the three brass colored power studs 1, 2, and 3 shown in figure #1 & 2. Secure connection by using 2 open ended 7/16" wrenches (one to hold the bottom terminal nut in place and the other to tighten the wire connection)

Care must be taken to not over tighten the lower torque nut as it could result in the cracking of the insulator sleeve.

- Assemble the two white overload wires (item#3) on the two overload studs black nuts 8 and 9 shown in figure #1 & 2. The white wires have spade terminals. Secure connection by using 2 open ended 7/16" wrenches (one to hold the bottom terminal nut in place and the other to tighten the jam nut (item# 8).

Front terminal

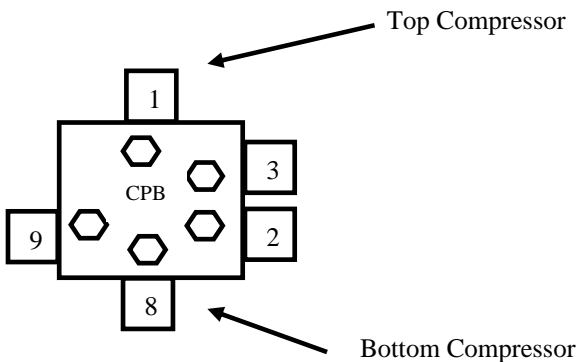

Figure # 1

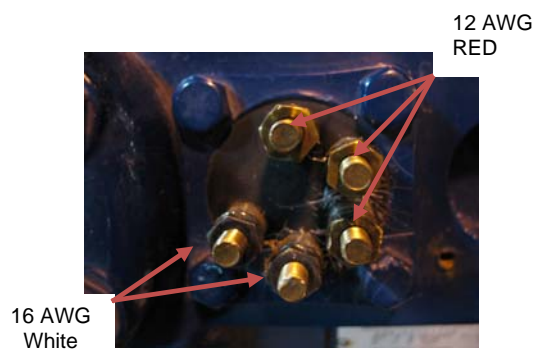



Figure # 2

- Bend the two white overload wires 90 degrees so that they pointing straight out from the compressor in alignment with the mounting screw see figure 3.
- Slide the large heat shrink tube (item #6) over each wire until it bottoms out against the terminal block. The sleeve must completely cover the isolator bushing (Item #5) see Figure 3.
- Use a heat gun to shrink the tubing in place as seen below see Figure 4.

<u>Used On:</u>	<u>Prepared By:</u>	<u>Approved By:</u>	<u>Date:</u>
-----------------	---------------------	---------------------	--------------

	No.: 62-90119-00	Rev: D
Title: Compressor Terminal Wiring Instructions	Supersedes:	Page: 4 of 5

15. After power leads and overload wires have been attached to the compressor, re-attached the box to the compressor and secure with bolts.

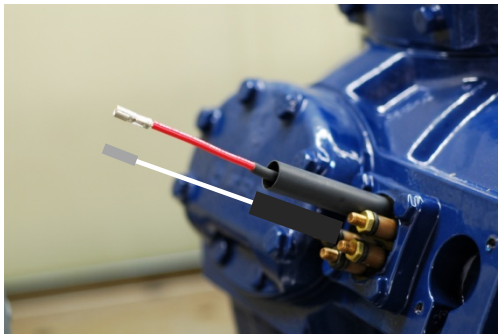

Figure #3

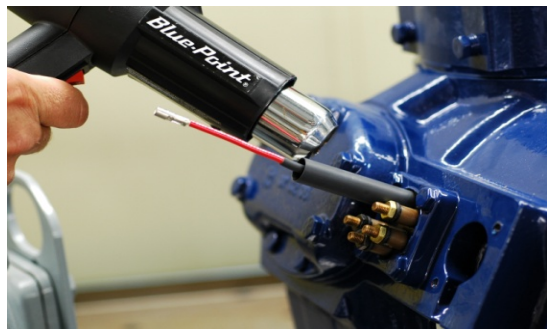
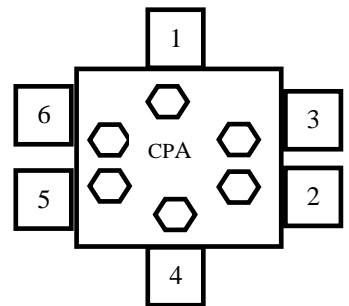

Figure # 4

PROCEED TO STEP 16 FOR A DUAL VOLTAGE APPLICATION, OR IF USING A DAUL VOLTAGE COMPRESOR IN A SINGLE VOLTAGE APPLICATION. IF NOT PROCEED TO STEP 26

Rear Terminal Block

16. At the rear terminal box, using wire cutters, cut the power leads as close to the compressor terminals as possible.
17. Remove the retaining screws holding the cover box to the compressor and remove box.
18. Remove the compressor wires from the terminals.
19. Remove the retaining nuts and washers from each of the terminals and save for later use.
20. Remove the insulator and rubber bushings and discard.
21. Install the RED ring terminal power wire (item # 2) to terminal 4 and bend it 90 degrees to the front of the compressor (figure # 3) as completed in step # 11 using the clinch nut (item # 8).
22. Install the five RED power wires (item#1) to the rear terminal block #s 1, 2,3,5,6 as completed in step #10.
23. Slide the large heat shrink tube (item # 5) over each wire until it bottoms out against the terminal block. The sleeve must completely cover the bushing (Item 4), see figure 3.
24. Use a heat gun to shrink the tubing in place, see figure 4.



Electrical Check (Meg-ohm Connections)

25. Before proceeding further, the terminal assembly should be checked for water tightness using a megohm meter (500 V-dc).
26. Connect the ground lead to the unit and spray each terminal box with a mist of water.

<u>Used On:</u>	<u>Prepared By:</u>	<u>Approved By:</u>	<u>Date:</u>
-----------------	---------------------	---------------------	--------------

	No.: 62-90119-00	Rev: D
Title: Compressor Terminal Wiring Instructions	Supersedes:	Page: 5 of 5

27. Record the reading of each wire lead to ground. Readings should be from 2 megohms to infinity. Readings less than 2 megohms indicate moisture may be present in the terminal stud gaskets and they must be reworked.

- Causes of megohm failures are:
- Cracked bushing (overtorque)
 - Torn or improperly assembled O-ring
 - Fiber washers saturated with water or oil
 - Incorrect assembly of heat shrinkable sleeve

Wiring in compressors

28. Replace terminal box on both the front and rear of the compressor.
 29. Strip back each wire 3/8inch (1.0 cm) from harness;
 30. Place a piece of 1/4" shrink tube over each of the wires and connect the harness wires to the proper wire using proper crimping tool. (Refer to unit wiring schematic or pictorial diagram.)

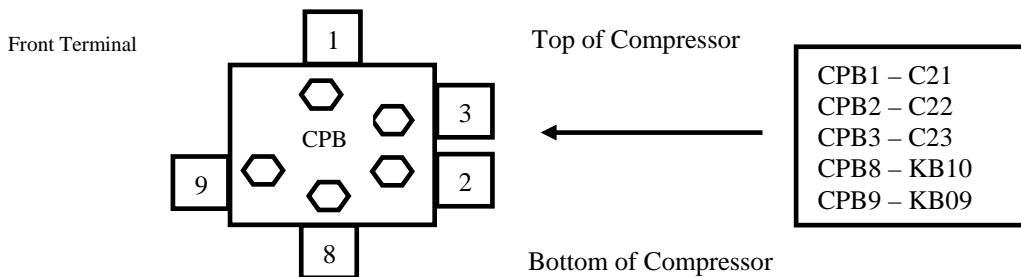

To wire a dual voltage compressor for single voltage

To wire a dual voltage by switch

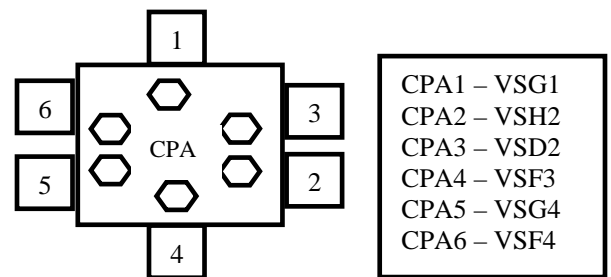
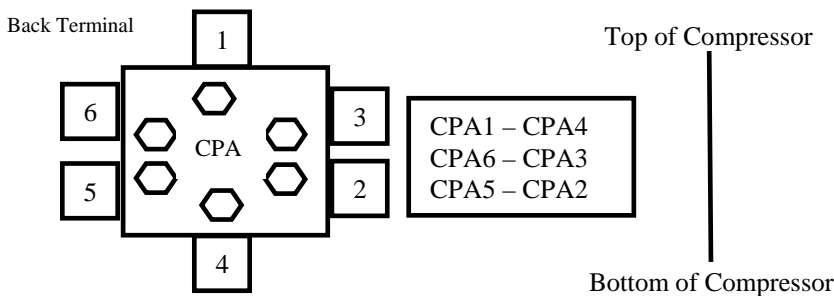

31. Use a heat gun to shrink the tubing.
 32. Carefully push the wires inside of the terminal box (applying a little heat using the heat gun assists in positioning the wires).
 33. Reinstall both front and rear terminal box covers
 34. Install or reinstall compressor if it was removed following procedure outlined in your service manual.

<u>Used On:</u>	<u>Prepared By:</u>	<u>Approved By:</u>	<u>Date:</u>
-----------------	---------------------	---------------------	--------------